

REVISIONS		DATE	APPROVED
ZONE	REV.	DESCRIPTION	
	1	PROTOTYPE	10.05.2021
	2	CHANGED UNIFIED THREAD DEFINITION CHANGED PASSIVATION STANDARD ADDED HEX SOCKET WIDTH	22.03.2024

COMPUTER GENERATED DRAWING
MANUAL CHANGES PROHIBITED

- NOTES:**
- ALL DIMENSIONS ARE IN MM.
 - MATERIAL:**
 - WEDGES AND SHAFT ARE AL6061-T6.
 - SCREW, PLAIN WASHER, LOCK WASHER AND SPIRAL PIN ARE CORROSION RESISTANT STEEL.
 - FINISH:**
 - WEDGES AND SHAFT: SEE TABLE 1.
 - SCREW, PLAIN WASHER, LOCK WASHER AND SPIRAL PIN: PASSIVATED IN ACCORDANCE WITH AMS2700F.
 - WEIGHT IS INDICATED IN TABLE 2.

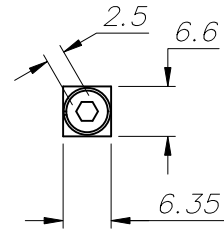
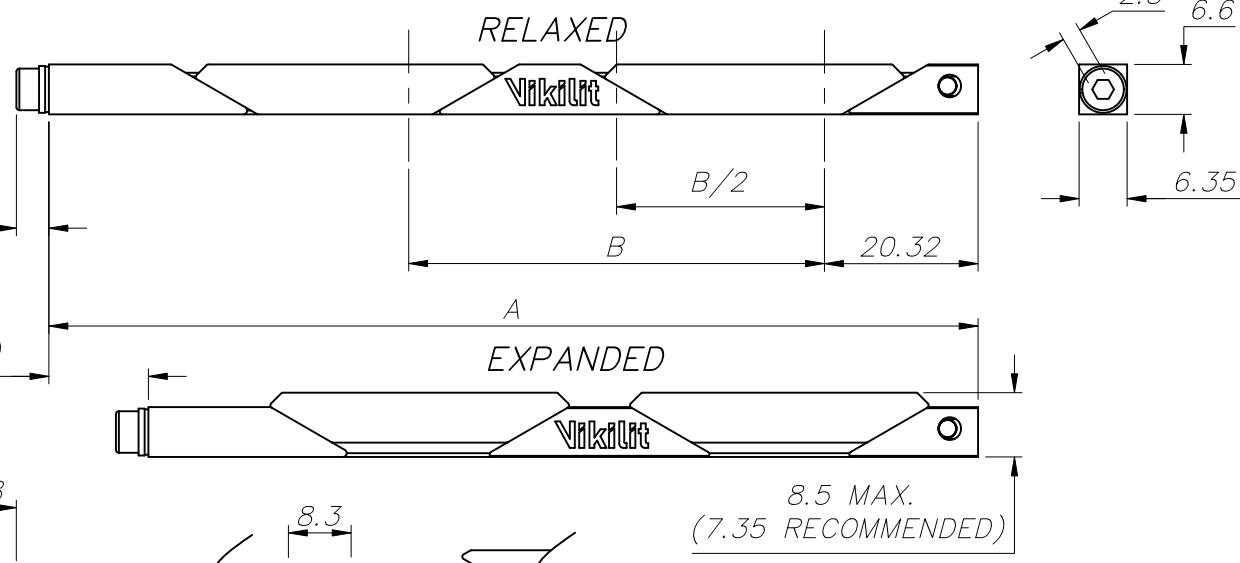
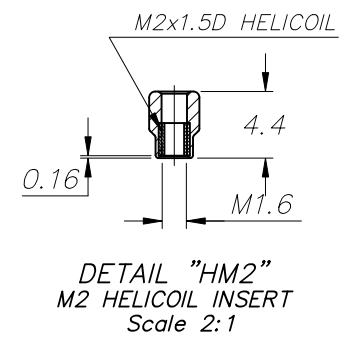
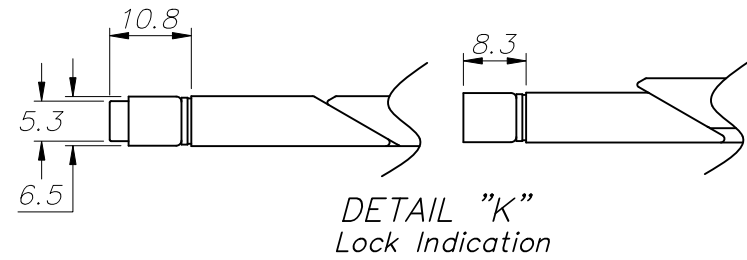
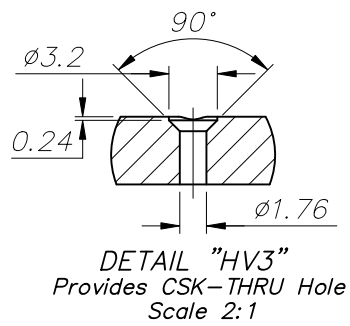
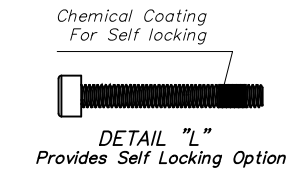
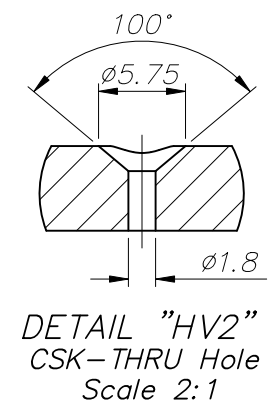
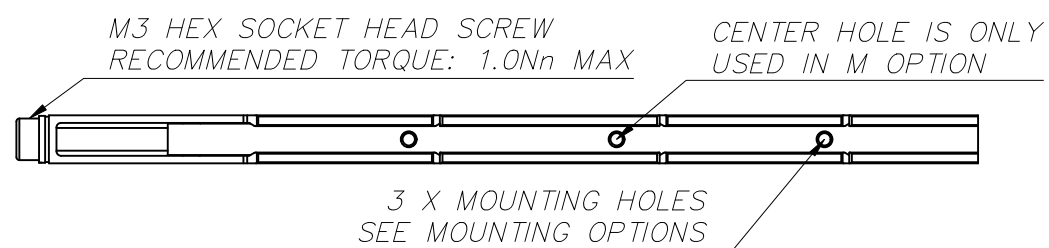

ASSEMBLY LENGHT CODE	A±1.00	HOLE DISTANCE	B	C	APPROX. WEIGHT (g)
072*	72.12	S	11.43	6.93	9
		A/M	19.00		
085*	84.82	S	17.78	6.93	10
		A/M	31.00		
099	97.52	S	24.13	13.16	11
		A/M	30.00		
112	110.22	S	30.48	13.16	12
		A/M	36.83		
125	122.92	S	36.83	13.16	14
		A/M	55.00		
138	135.62	S	43.18	13.16	15
		A/M	66.00		
150	148.32	S	49.53	13.16	16
		A/M	79.00		
163	161.02	S	55.88	13.16	17
		A/M	87.00		
175	173.72	S	62.23	13.16	19
		A/M	92.50		
187**	186.42	S	68.58	13.16	20
		A/M	100.00		
200**	199.12	S	74.93	19.80	21
		A/M	112.00		
212**	211.82	S	81.28	19.80	22
		A/M	125.00		
225**	224.52	S	87.63	19.80	24
		A/M	138.00		

*: THREE WEDGE DESIGN
**: SEVEN WEDGE DESIGN

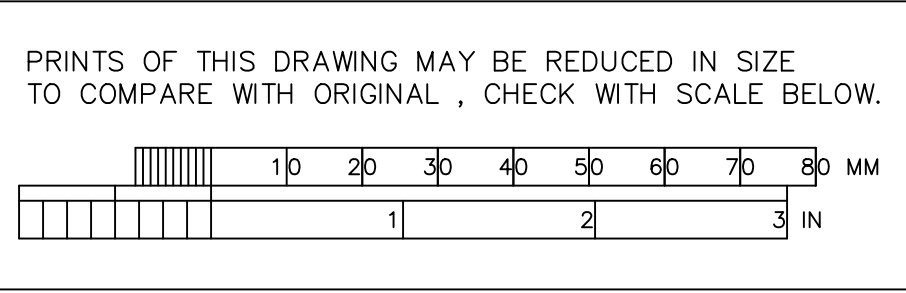

UNLESS OTHERWISE SPECIFIED DIMENSIONS ARE IN MM		CONTRACT NO. --		Harp Savunma Sistemleri San. ve Tic. A.Ş. Bilkent Cyberpark, Cyber Plaza B Blok, No:216 Çankaya/Ankara			
TOLERANCES ON		DRAFTS					
FRACTIONS ±		DFT SUPV		VK635-SERIES			
GENERAL X.X ±0.2		ENGR					
X.XX ±0.10		CHECK		HARP-VK-127			
REMOVE ALL BURRS		APPD ME					
MATERIAL:		STAFF ENGR.		SIZE	FSCM NO.	DWG NO.	REV.
SEE NOTE 2		QA/QC		A3	--	HARP-VK-127	2
FINAL PROTECTIVE FINISH:		MFG(FAB)		SCALE	1/1	UNIT	mm
SEE NOTE 3		PROD ENG		SHEET		1 OF 1	
NEXT ASSY	USED ON	APPLICATION					