

COMPUTER GENERATED DRAWING
MANUAL CHANGES PROHIBITED

REVISIONS				
ZONE	REV.	DESCRIPTION	DATE	APPROVED
	1	PROTOTYPE	03.09.2024	

NOTES:

- 1- ALL DIMENSIONS ARE IN MM.
- 2- MATERIAL:
 - WEDGES: AL6061-T6.
 - SCREW, SQUARE WASHER, PINS: CORROSION RESISTANT STEEL.
- 3- FINISH:
 - WEDGES: SEE TABLE 1
 - SCREW, SQUARE WASHER, PINS: PASSIVATED IN ACCORDANCE WITH AMS2700F.
- 4- WEIGHT IS 14.3 GR.
- 5- MAX. THREAD DEPTH: 2 MM.

Chemical Coating
For Self locking

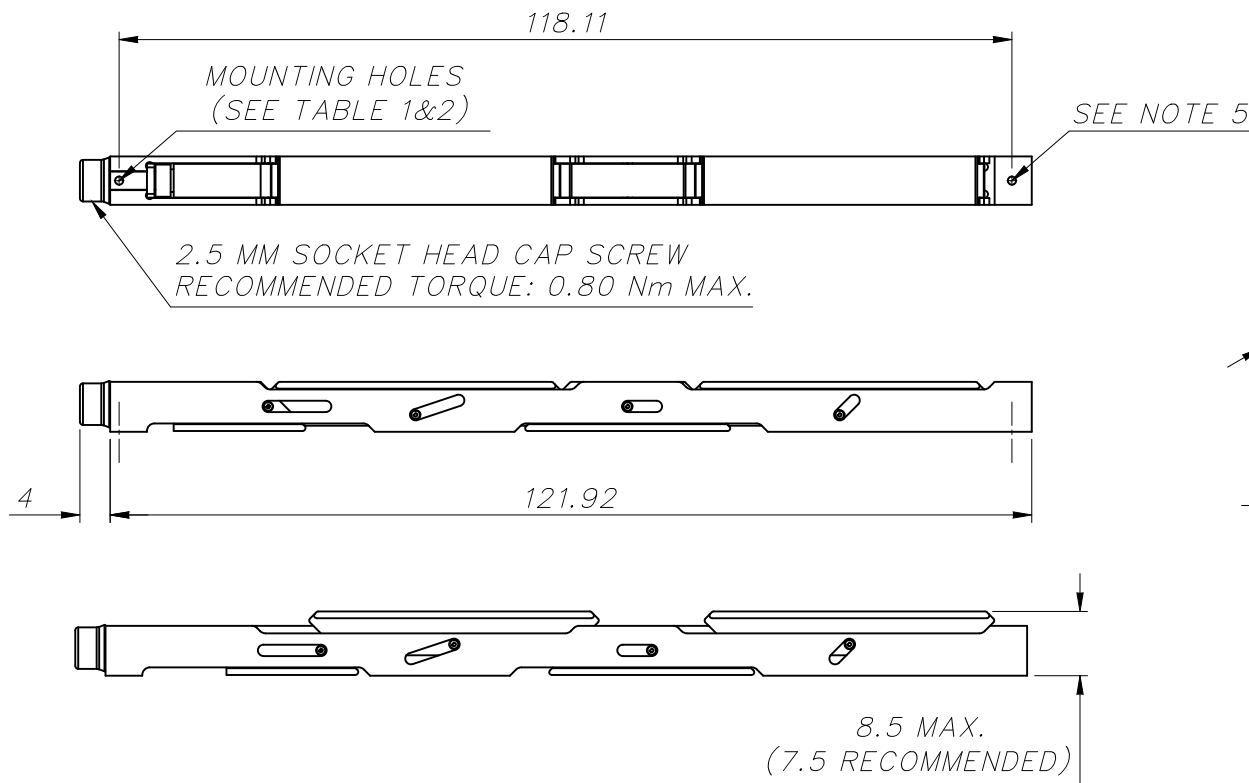
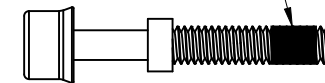

TABLE 1

VP640 - 4.8 - LM25

Options:

MANUFACTURER TYPE CODE	_____
Assembly Length Code	_____
Black Anodize per MIL-A-8625 Type II, Class 2	_____ A
Hard Black Anodize per MIL-A-8625 Type III, Class 2	_____ HA
Electroless Nickel per MIL-C-26074 Class 4, Grade B, Bright	_____ EN
Chromate per MIL-DTL-5541, Class 1A, Yellow	_____ L
Mounting Options	M2.5x0.45 Tapped Hole _____ M25
	M2.0x0.40 Tapped Hole _____ M20
	2-56 Tapped Hole _____ U2
	0-80 Tapped Hole _____ U0

PRINTS OF THIS DRAWING MAY BE REDUCED IN SIZE
TO COMPARE WITH ORIGINAL, CHECK WITH SCALE BELOW.

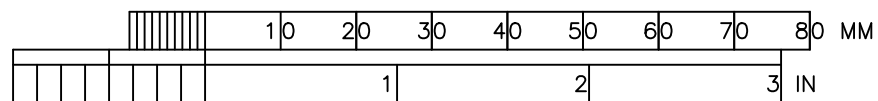

UNLESS OTHERWISE SPECIFIED DIMENSIONS ARE IN MM		CONTRACT NO. --		Harp Savunma Sistemleri San. ve Tic. A.Ş. Bilkent Cyberpark, Cyber Plaza B Blok, No:216 Çankaya/Ankara	
TOLERANCES ON		DRAFTS		S.YILMAZ	
FRACTIONS ± ANGLES ± 2°		DFT SUPV		S.YILMAZ	
GENERAL X.X ±0.2		ENGR		S.YILMAZ	
X.XX ±0.10		CHECK		M.YENER	
REMOVE ALL BURRS		APPD		ME	
MATERIAL:		EE			
SEE NOTE 2		STAFF ENGR.		SIZE	
SEE NOTE 3		QA/QC		F3	
FINAL PROTECTIVE FINISH:		MFG(FAB)		FSCM NO.	
NEXT ASSY		PROD ENG		--	
USED ON				DWG NO.	
APPLICATION				HARP-VK-134	
				REV.	
				1	
		SCALE 1/1		UNIT mm	
				SHEET 1 OF 1	